

Pioneer Solid-State Lithium-ion Battery ESS



- High-performance high-voltage storage system.
- Modular design for ultimate flexibility.
- Suitable for a wide range of applications.
- Expandable up to 208.98 kWh(13S) capacity.

PRODUCT FEATURES



Ultra safe with
solid-state battery cells



Built-in fire extinguishing
system(optional)



SOC balancing between
clusters



Easy installation:save
time and costs



Flexible expansion: up to
8 clusters in parallel



Built-in
intelligent BMS



WAN Port in additon
to WIFI

● Technical Specifications

Battery Module Image		
Model	LFP 16076SM	LFP 16076S
Battery Type	Semi-solid state Prismatic	
Nominal Energy	16.076kWh	
Usable Energy*	14.95kWh	
Nominal Capacity	314Ah	
Nominal Voltage	51.2V	
Operating Voltage	48~56V	
Recommended Charge&Discharge Current	150A/150A	
Peak Discharge Current (2min 25℃)	175A	
Peak Discharge Power (2min 25℃)	8.96kW	
Recommended Depth of Discharge (DOD)	93%	
Charging Temp. Range	From 0~55℃	
Discharging Temp. Range	From -20~55℃	
Cycle Life	≥8000@25℃	
Scalability	1 Master series	Up to 12Slave series
WIFI Module	Uhome	
Communication	CAN/ RS485	
IP Rating	IP65	
Recommended Humidity	5%~95%(No condensed water)	
Cooling Type	Forced cooling	
Color	White(optional)	
Installation	Stack-mounting	
Net Weight	125kg	
Dimension (W*H*D)	755*465*270mm	
Protection	Over-current/Over-voltage/Short circuit/Under-voltage/Over temperature	
Heating Module	Yes	
Balancing Module	Yes	
Fire Protection	Built-in aerosol(optional)	
Warranty	10 years*	
Certification	CE/UN38.3/IEC62619/IEC62477	

Testing conditions based on temperature 25℃ at the beginning of life.

*Total Energy/Usable Energy measured under specific conditions by Uhome 0.2C CC-CV and based on recommended DOD(95%);

● Technical Specifications

Model	64.30kWh	80.38kWh	96.46kWh	112.53kWh
Battery Type	Semi-solid state Prismatic			
Nominal Energy	64.30kWh	80.38kWh	96.46kWh	112.53kWh
Usable Energy*	59.80kWh	74.75kWh	89.70kWh	104.65kWh
Nominal Capacity	314Ah			
Nominal Voltage	204.8V	256V	307.2V	358.4V
Operating Voltage	192~224V	240~280V	288~336V	336~392V
Recommended Charge&Discharge Current	150A/150A			
Peak Discharge Current (2min 25℃)	175A			
Peak Discharge Power (2min 25℃)	35.84kW	44.80kW	53.76kW	62.72kW
Recommended Depth of Discharge (DOD)	93%			
Charging Temp. Range	From 0~55℃			
Discharging Temp. Range	From -20~55℃			
Cycle Life	≥8000@25℃			
Scalability	4S	5S	6S	7S
WIFI Module	Uhome			
Communication	CAN/ RS485			
IP Rating	IP65			
Recommended Humidity	5%~95%(No condensed water)			
Cooling Type	Forced cooling			
Color	White(optional)			
Installation	Stack-mounting			
Net Weight	500kg	625kg	750kg	875kg
Dimension (W*H*D)	755*1860*270mm	755*2325*270mm	755*2790*270mm	/
Protection	Over-current/Over-voltage/Short circuit/Under-voltage/Over temperature			
Heating Module	Yes			
Balancing Module	Yes			
Fire Protection	Built-in aerosol(optional)			
Warranty	10 years*			
Certification	CE/UN38.3/IEC62619/IEC62477			

Testing conditions based on temperature 25℃ at the beginning of life.

*Total Energy/Usable Energy measured under specific conditions by Uhome 0.2C CC-CV and based on recommended DOD(95%);

NOTICE:When the number of stacks exceeds 6, please place them in two or more separate piles.

● Technical Specifications

Model	128.61kWh	144.68kWh	160.76kWh
Battery Type	Semi-solid state Prismatic		
Nominal Energy	128.61kWh	144.68kWh	160.76kWh
Usable Energy*	119.61kWh	134.56kWh	149.51kWh
Nominal Capacity	314Ah		
Nominal Voltage	409.6V	460.8V	512V
Operating Voltage	384~448V	432~504V	480~560V
Recommended Charge&Discharge Current	150A/150A		
Peak Discharge Current (2min 25℃)	175A		
Peak Discharge Power (2min 25℃)	71.68kW	80.64kW	89.6kW
Recommended Depth of Discharge (DOD)	93%		
Charging Temp. Range	From 0~55℃		
Discharging Temp. Range	From -20~55℃		
Cycle Life	≥8000@25℃		
Scalability	8S	9S	10S
WIFI Module	Uhome		
Communication	CAN/ RS485		
IP Rating	IP65		
Recommended Humidity	5%~95%(No condensed water)		
Cooling Type	Forced cooling		
Color	White(optional)		
Installation	Stack-mounting		
Net Weight	1000kg	1125kg	1250kg
Dimension (W*H*D)	/	/	/
Protection	Over-current/Over-voltage/Short circuit/Under-voltage/Over temperature		
Heating Module	Yes		
Balancing Module	Yes		
Fire Protection	Built-in aerosol(optional)		
Warranty	10 years*		
Certification	CE/UN38.3/IEC62619/IEC62477		

Testing conditions based on temperature 25℃ at the beginning of life.

*Total Energy/Usable Energy measured under specific conditions by Uhome 0.2C CC-CV and based on recommended DOD(95%);

NOTICE:When the number of stacks exceeds 6, please place them in two or more separate piles.

● Technical Specifications

Model	176.83kWh	192.91kWh	208.99kWh
Battery Type	Semi-solid state Prismatic		
Nominal Energy	176.83kWh	192.91kWh	208.99kWh
Usable Energy*	164.46kWh	179.41kWh	194.36kWh
Nominal Capacity	314Ah		
Nominal Voltage	563.2V	614.4V	512V
Operating Voltage	528~616V	576~672V	624~728V
Recommended Charge&Discharge Current	150A/150A		
Peak Discharge Current (2min 25℃)	175A		
Peak Discharge Power (2min 25℃)	98.56kW	107.52kW	116.48kW
Recommended Depth of Discharge (DOD)	93%		
Charging Temp. Range	From 0~55℃		
Discharging Temp. Range	From -20~55℃		
Cycle Life	≥8000@25℃		
Scalability	11S	12S	13S
WIFI Module	Uhome		
Communication	CAN/ RS485		
IP Rating	IP65		
Recommended Humidity	5%~95%(No condensed water)		
Cooling Type	Forced cooling		
Color	White(optional)		
Installation	Stack-mounting		
Net Weight	1375kg	1500kg	1625kg
Dimension (W*H*D)	/	/	/
Protection	Over-current/Over-voltage/Short circuit/Under-voltage/Over temperature		
Heating Module	Yes		
Balancing Module	Yes		
Fire Protection	Built-in aerosol(optional)		
Warranty	10 years*		
Certification	CE/UN38.3/IEC62619/IEC62477		

Testing conditions based on temperature 25℃ at the beginning of life.

*Total Energy/Usable Energy measured under specific conditions by Uhome 0.2C CC-CV and based on recommended DOD(95%);

NOTICE:When the number of stacks exceeds 6, please place them in two or more separate piles.

● Reference scheme wiring diagram

Wiring diagram for 12 units (divided into 2 piles)



Wiring diagram for 12 units (divided into 3 piles)

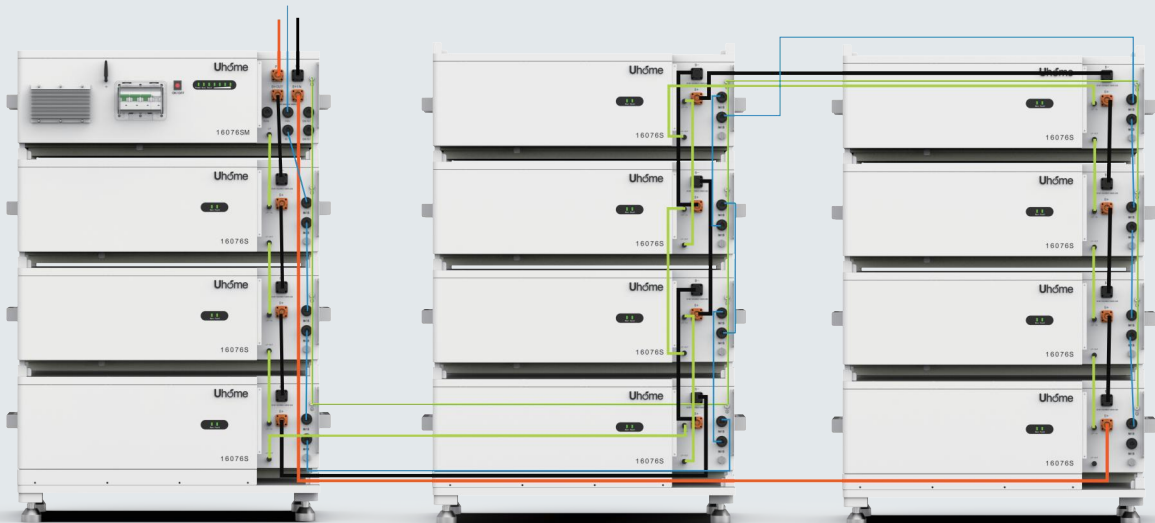

Product Advantages

What is Semi-Solid State

In solid-state lithium-ion batteries, lithium ions travel between electrodes through a solid electrolyte during the charging and discharging processes. However, full solid-state batteries encounter challenges related to limited contact efficiency between the electrodes and the electrolyte. To overcome this issue, a promising solution is to incorporate small amounts of liquid electrolytes, which can optimize battery performance and extend lifespan.

Semi-solid state batteries, the 1st generation of all solid state, offer enhanced safety compared to traditional LFP batteries, as the solid components significantly reduce the risk of leakage. Additionally, the special small amounts inclusion of liquid electrolytes improves ion conductivity, thereby enhancing overall battery performance.



The core and barrier of solid-state LIBs is the innovative development of materials.



Our products have undergone multiple rigorous tests.

Core Advantages

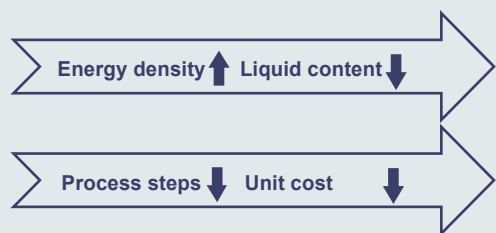
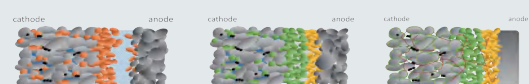
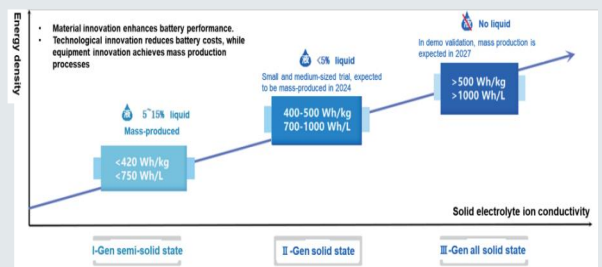
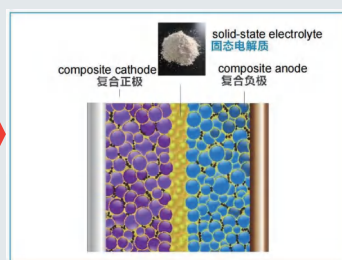
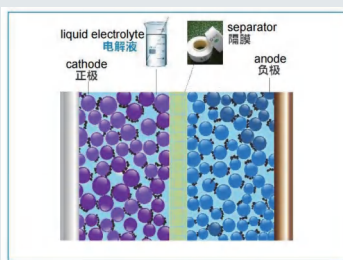

MUCH SAFER:The liquid electrolyte content of semi-solid state batteries is reduced to 5% -10%, and the semi-solid structure significantly reduces the risk of leakage. The solid-state electrolyte layer suppresses lithium dendrite growth and reduces the probability of thermal runaway.

LONGER SPAN LIFE:Solid electrolytes slow down the corrosion and volume expansion of electrode materials, improving long-term stability.

HIGHER COST-EFFECTIVENESS:The semi-solid state battery adopts in-situ solidification technology, and only requires partial modification of the liquid battery production line to achieve mass production, greatly reducing equipment investment costs.

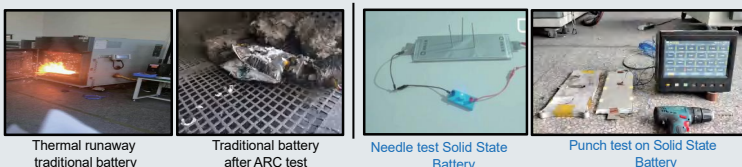

300°C ARC Test (Accelerating Rate Calorimeter)		
Items	Solid state LFP Battery	Traditional LFP
Max. temperature rise rate (dT/dt) _{max} (°C/S)	0.235	2.129
Temperature point T _{max} (°C)	No thermal runaway	471.4

Note: Definition conditions for thermal runaway, temperature rise rate dT/dt ≥ 1°C/S

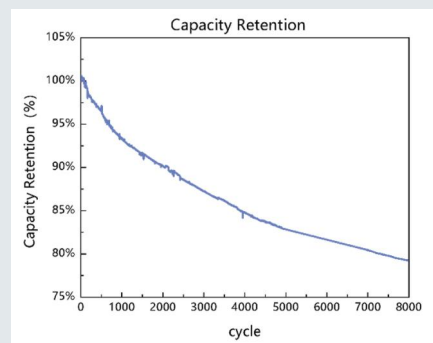

- High Safety
- Long Battery Life
- More affordable

● Product Advantages

Built-in Aerosol Fire Protection System(Optional)



Security upgrade and fire protection are guaranteed

The aerosol spray is white, green is used for better visibility while illustrating.

Core Advantages

Insulation and thermal runaway protection:

The thermal conductivity of aerogel is extremely low ($0.013 - 0.025 \text{ W}/(\text{m} \cdot \text{K})$), only $1/5 - 1/3$ of that of traditional materials, and can effectively block heat transfer between electric cores;

Excellent flame retardant performance:

Silica aerogel can withstand temperature as high as 800°C without decomposition, which is superior to traditional polyurethane and other materials, significantly reducing fire risk;

Capable of quickly extinguishing fires:

The hot aerosol fire extinguishing device can release an abundance of inert gas within 10-13 seconds, quickly extinguishing fires in enclosed spaces such as data cabinets;

Lightweight design:

The density of aerogel is as low as $0.16 \text{ mg}/\text{cm}^3$ (all carbon aerogel), and the thickness is only $1/5 - 1/3$ of that of traditional materials under the same thermal insulation effect, which can reduce the weight of battery pack and increase the energy density by $5\% - 10\%$;

More environmentally friendly and cost-effective:

The aerogel life cycle is 4 times that of traditional materials, and long-term use reduces maintenance costs;

● Product Advantages

SOC Balancing Between Clusters

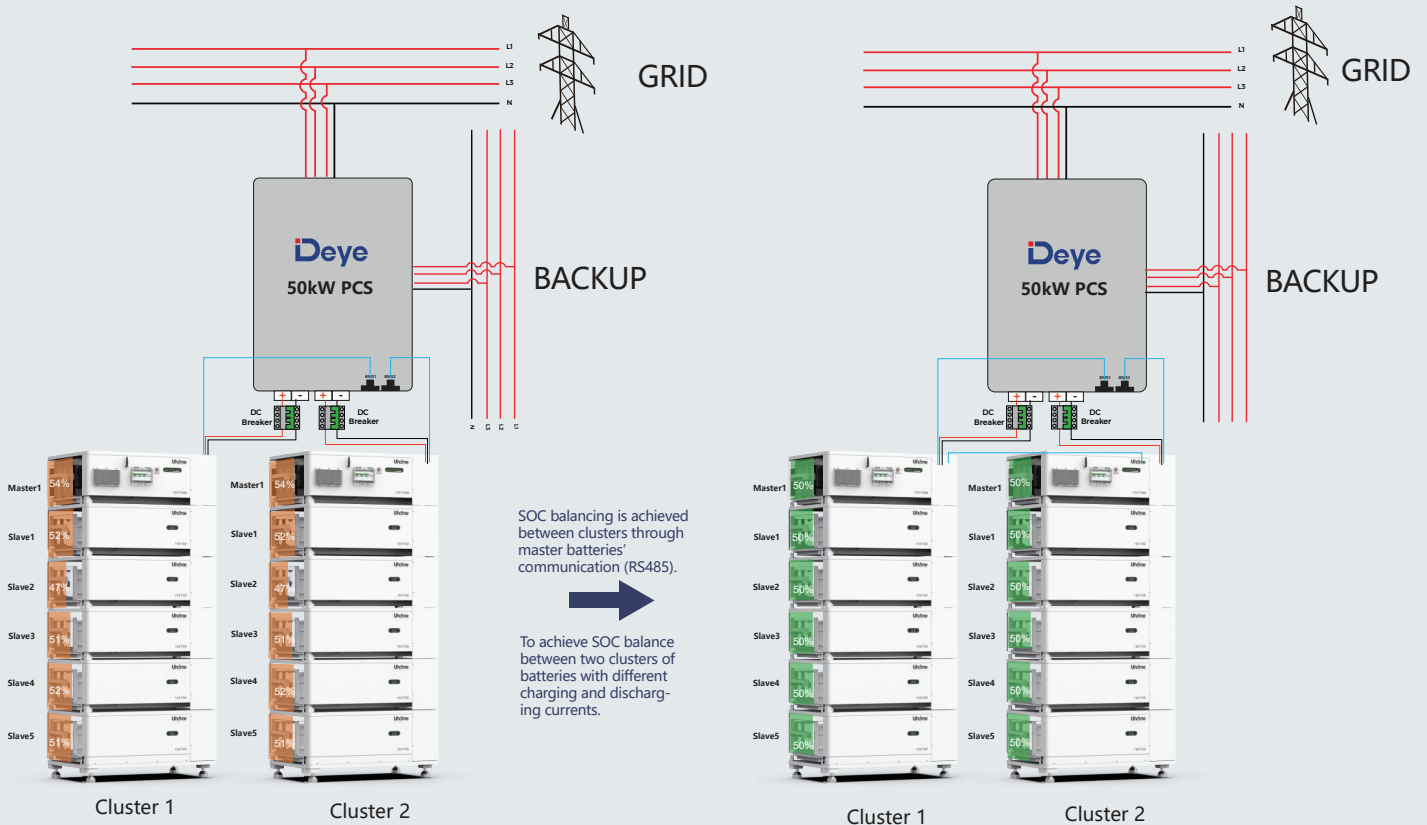

NOTICE:

In the case of multiple cluster batteries, the universal wiring for parallel operation of the host is shown in the following figure :

